

iBox protection box

Innovative and streamlined

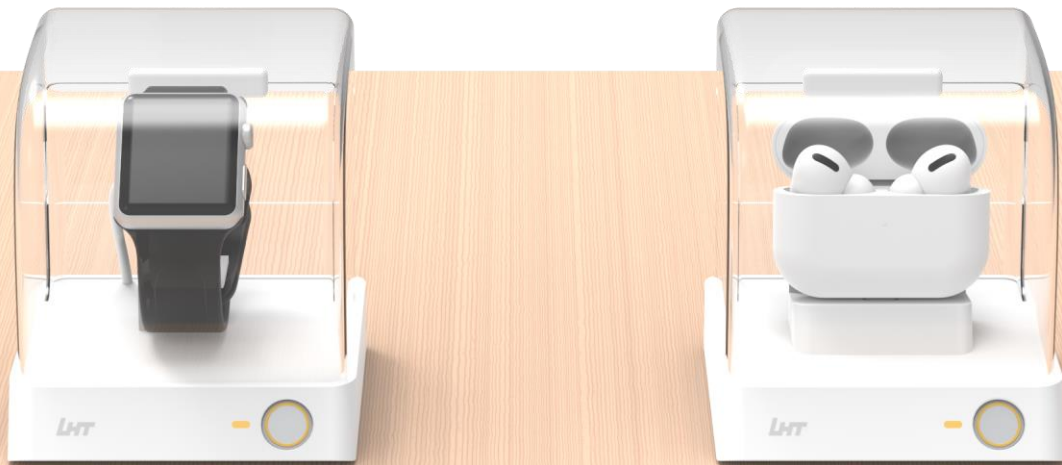

The iBox protection box is designed with an alarm detection system and a transparent dust protection cover, which is especially suitable for the display EarPods, watches, lenses, perfumes and other products.

iBox090

Features

- Square Alarm Base : 95*95*90mm;
- Suitable for adhesive, screw installation;
- Support using charging cable (cable can go through from bottom or side) ;
- Double alarm design :illegal removal + illegal opening ;
- Alarm Sound≥90DB(10cm);
- Easy to open and unlock;
- AAA*2 battery (Need to purchase locally);
- Accept OEM for transparent protective cover on demand ;

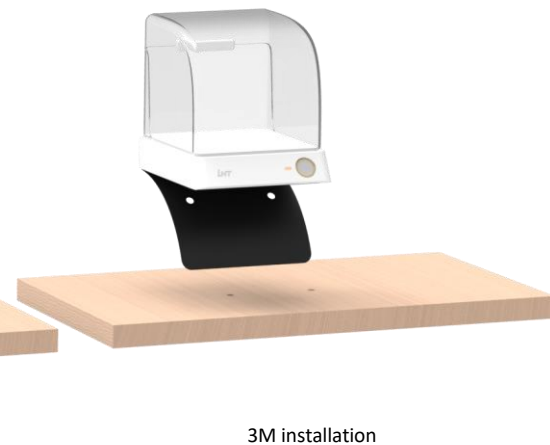
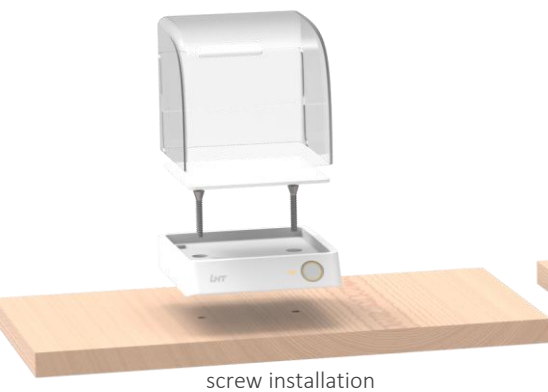
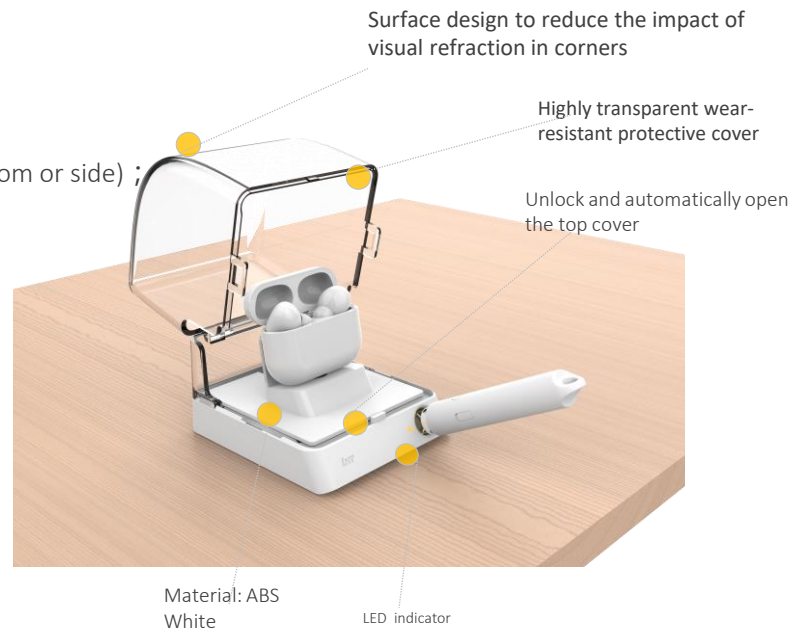

1. Detachable stand design
The display of different products only needs to change the plastic support. And the default selection is watch stand.
2. The charging cable can go through the ibox



Order List

Core components		
Model	Product Description	Color
iBox010W	The base of Ibox	White
iBox501T	90mm Highly transparent cover assembly	White
iBox400W	Alarm box Plastic Support --flat	White
iBox090T	90mm transparent cover (iBox010W+iBox501T+iBox400W)	White
SK100W	Remote Control 2.4G	White